

## Coil springs



### Additional information

- Stainless Steel 304
- Weight range – 3 lbs to 8 lbs
- Stamped with weight for easy identification
- To be used with monobloc cassettes or standard spring support

### Dimensions in mm

A = Short tail 23,0 – Medium tail 58,0 – Long tail 104,0  
 B = Range 27,5 to 31,5

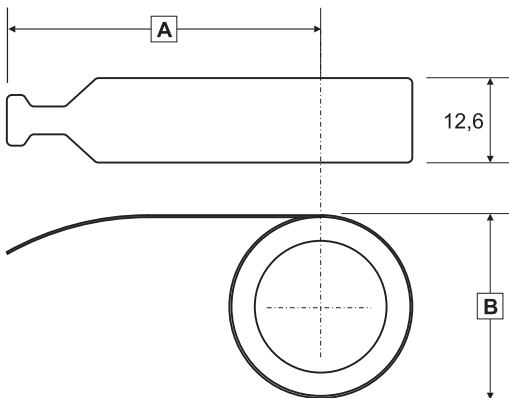

### Constant force coil springs

Description	Weight (lbs)	Color	PU	Part Number
Coil with short tail	3*	Stainless Steel	100	9-C1531-1C-0-0
			500	9-C1531-5C-0-0
	4	Stainless Steel	100	9-C1541-1C-0-0
			500	9-C1541-5C-0-0
	5	Stainless Steel	100	9-C1551-1C-0-0
			500	9-C1551-5C-0-0
	6	Stainless Steel	100	9-C1561-1C-0-0
			500	9-C1561-5C-0-0
7	Stainless Steel	100	9-C1571-1C-0-0	
		500	9-C1571-5C-0-0	
8	Stainless Steel	100	9-C1581-1C-0-0	
		500	9-C1581-5C-0-0	
Coil with medium tail	3	Stainless Steel	100	9-C1532-1C-0-0
			500	9-C1532-5C-0-0
	4	Stainless Steel	100	9-C1542-1C-0-0
			500	9-C1542-5C-0-0
	5	Stainless Steel	100	9-C1552-1C-0-0
			500	9-C1552-5C-0-0
	6	Stainless Steel	100	9-C1562-1C-0-0
			500	9-C1562-5C-0-0
7	Stainless Steel	100	9-C1572-1C-0-0	
		500	9-C1572-5C-0-0	
8	Stainless Steel	100	9-C1582-1C-0-0	
		500	9-C1582-5C-0-0	
Coil with long tail	3	Stainless Steel	100	9-C1533-1C-0-0
			500	9-C1533-5C-0-0
	4	Stainless Steel	100	9-C1543-1C-0-0
			500	9-C1543-5C-0-0
	5	Stainless Steel	100	9-C1553-1C-0-0
			500	9-C1553-5C-0-0
	6	Stainless Steel	100	9-C1563-1C-0-0
			500	9-C1563-5C-0-0
7	Stainless Steel	100	9-C1573-1C-0-0	
		500	9-C1573-5C-0-0	
8	Stainless Steel	100	9-C1583-1C-0-0	
		500	9-C1583-5C-0-0	

\* Only available on special request

\* = Color

PU = Packaging Unit