

Brake shoe and retainer clip for constant force



Front and side locking brake shoe and pivot bar retainer clip

Description	Color	PU	Part Number
Front and side locking brake shoe	Ivory	200	6-C1523-2C-0-0
		1000	6-C1523-1M-0-0
Pivot bar retainer clip	Ivory	200	9-C1512-2C-0-0
		1000	9-C1512-1M-0-0

* = Color

PU = Packaging Unit

Additional information

- Brake shoe made of fiberglass reinforced nylon
- Spring slots closer to center of shoe to reduce torsion of shoe in track
- Reinforced spring slot designed to withstand greater pull force
- All edges are rounded to reduce friction
- Can be used for horizontal sliders
- Brake will engage with as little as 15° of sash turn
- Optional retainer clip (for horizontal sliders mandatory)

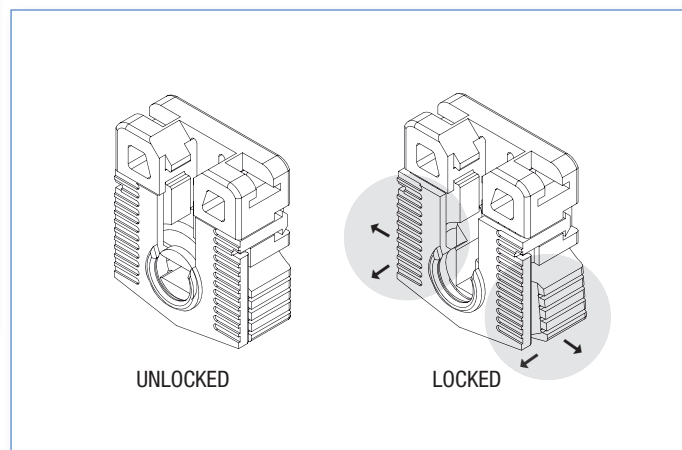
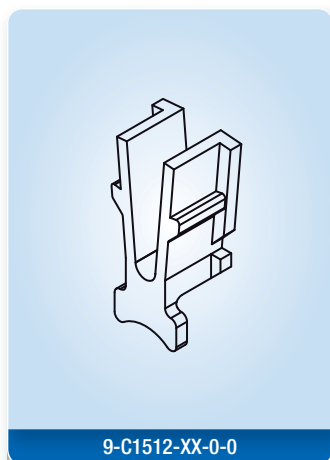

Dimensions in mm

